



# RED RHINO 4000 SERIES

## OPERATION & MAINTENANCE HANDBOOK



Serial Number	4011065
Date of manufacture	January 2023

Publication Number	411001
Publication Date	July 2022



Red Rhino  
Crushers (UK) Ltd  
Isaac Newton Way  
Grantham  
Lincolnshire  
NG31 9RT  
United Kingdom

Tel: +44 (0) 1476 590 790  
E-mail: [info@redrhinocrushers.net](mailto:info@redrhinocrushers.net)  
Web: [www.redrhinocrushers.com](http://www.redrhinocrushers.com)





**The purpose of this manual is to give a quick reference to the owner and operators of the Red Rhino 4000 Series.**

**For more Technical, Maintenance and Operational Information please refer to the following:**

**Kubota Engine Operations Manual**

**Red Rhino Technical / Service Department**

**Email: [service@redrhinocrushers.net](mailto:service@redrhinocrushers.net)**

**Telephone: +44 (0) 1476 590 790**

## Contents

Terms & Definitions.....	5
Warranty.....	6-8
Warranty Registration and Installation Certificate.....	9-10
EU Declaration of Conformity.....	11
Introduction to the Handbook.....	12-14
Warning Labels & Symbols.....	15
Stopping the Machine in an Emergency.....	16
Component Locations.....	17-18
General Safety.....	19-21
Operating Safety.....	22-24
Maintenance Safety.....	25
Crushing.....	26-27
Operation Instructions.....	28
Pre-Start Safety Checks.....	29
Guidance to Machine Pre-Start Checks.....	30-31
Engine Controls.....	32-33
Discharge Conveyor.....	34
Dust Suppression.....	35
Running Gears (Tracks).....	36
Track Adjustment.....	37
Jaw Crusher Unit.....	38-40
Guide to Servicing Your Machine.....	41-44
Cooling System.....	45
Hydraulics.....	46
Hydraulic Manual Controls.....	47
Deploying Machine into Crushing Operation.....	48
Closing the Machine Down After Crushing Process.....	49
Replacement Parts.....	50
Model Specifications.....	51
General Arrangement Dimension.....	52
Hydraulics Schematic.....	53
Electrical Components.....	54
Noise Emissions.....	55
Blank page for notes on individual conditions.....	56



## Terms & Definitions

For the purposes of this document, the terms and definitions given in ISO 6165 and the following apply.

### **Left-hand side**

Side which is on the left when an observer is facing in the normal forward direction of travel of the machine.  
[ISO 3600:1996]

### **Right-hand side**

Side which is on the right when an observer is facing in the normal forward direction of travel of the machine.  
[ISO 3600:1996]

### **Operator's manual**

Document describing and illustrating the safe operation, maintenance and safety precautions related to an earth-moving machine.



**Direction of Travel  
(Forward)**

# Warranty

## Warranty Terms, Conditions & Procedures

### Warranty Terms and Conditions.

Your Red Rhino 4000 series Compact Crusher has been designed and manufactured in the UK and meets all current EU legislation on safety, emissions and noise levels. The product is warranted against any defects in material and workmanship for a period of 1 year or 1000 hours usage from date of installation whichever occurs first.

#### **This warranty is subject to:**

Adherence to the routine maintenance procedures as detailed in the instruction book, the use of genuine Red Rhino parts and approved lubricants.

Adherence to the service schedule, undertaken by Red Rhino Crushers (UK) Ltd or an approved Red Rhino service agent, using genuine Red Rhino parts and approved lubricants.

Adherence to the requirement to utilize and record service actions with Red Rhino Crushers (UK) Ltd service record documentation, and to supply Red Rhino Crushers (UK) Ltd with originals of service record documentation.

Return (within 30 days) of a signed collection/delivery note confirming acceptance of goods in satisfactory condition, and all warranty registrations including: The Red Rhino Warranty Registration & Installation Certificate and Kubota engine manufacturers Warranty Certificate.

Adherence to the correct warranty claim procedure as stated below, including the provision of a valid purchase order number by the customer, and utilization of a valid Red Rhino Crushers (UK) Ltd reference number.

Subject to adherence to the above conditions and during the warranty period, any failed parts will be supplied free of charge, except for the following limitations:

#### **Warranty Limitations:**

The following items are consumable parts and not covered by warranty:

1. Tracks
2. Battery & Starter motor
3. Wear parts - crusher jaws, conveyor belts, toggle-plate, drive belts, conveyor roller lagging, internal and conveyor rubber wear parts.
4. Paintwork
5. Warranty exclusions as determined by the engine manufacturer:
6. Service parts - filters, glow-plugs, fanbelts, fuel injection equipment, stop solenoid, leaks (oil, water, and air) hoses, coolants and lubricants. Brake parts (where applicable).

Warranty does not extend to cover normal routine maintenance, cleaning, or servicing, nor any materials used to carry out routine servicing. The buyer hereby acknowledges and accepts that any costs incurred on repairs, mileage or servicing required outside of warranty periods or in the event that a warranty claim is rejected, will be chargeable at our standard rates. (Please contact us for further information).

All engine warranty issues must be directed to the engine manufacturer or the engine manufacturers approved / appointed engine dealer. No liability shall be attached to us where repairs cannot reasonably be affected, or where, following partial repair, a fault or breakdown occurs in the parts or portion not repaired.

The warranty liability of Red Rhino Crushers (UK) Ltd is restricted in all cases to the repair or replacement of the defective parts(s), and no liability is accepted for consequential damage or any other expense, loss, or costs (including loss of profit). Red Rhino Crushers (UK) Ltd may actuate the repair or provide compensation in the form of a credit note only, for labour incurred in actuating the repair. In all cases, a credit note for labour will only be provided for the replacement or repair of the defective part(s) and in accordance with the time allowances detailed in the Red Rhino workshop manual and limited in all cases to the standard hourly rate mentioned above.

**The warranty does not apply to defects caused by accident, misuse, neglect or wear and tear.**

Red Rhino Crushers (UK) Ltd warranty does not cover any indirect loss and/or expense or costs (including loss of profit), and Red Rhino Crushers (UK) Ltd are not liable for any such costs, loss or expense suffered arising out of a breach by Red Rhino Crushers (UK) Ltd of this contract.

The equipment is checked for contaminants in fuel, oils and lubricants prior to dispatch. If routine service or warranty work reveals any contamination in the fuels, engine, or hydraulic system, then the works carried out to amend the problem will be chargeable and not included within warranty.

The warranty is not transferable without written authority from Red Rhino Crushers (UK) Ltd.

Red Rhino Crushers (UK) Ltd cannot recognize any liability, in cases where alterations or modifications have been executed or replacement parts fitted other than those approved without prior knowledge and consent in writing from Red Rhino Crushers (UK) Ltd.

**Red Rhino will not be held responsible if:**

The machine has been used to perform tasks that demand more than its design and strength limitations.

Modifications, alterations, or the use service parts, consumables or lubricants which are not genuine or recommended will invalidate any warranty.

The machine has undergone modifications not approved in writing by Red Rhino Crushers (UK) Ltd, or conditions of use have been abnormal.

The conditions of warranty supply listed above have not been met.

Warranty does not extend to cover normal maintenance, cleaning, or servicing, nor any materials used to carry out routine servicing.

**FUNCTION**

The 4000 series: for the crushing and recycling of secondary debris and demolition waste materials of a size not exceeding the dimensions of the jaw-bite aperture. Not for primary mineral extraction. Not for use with reinforced material containing metals, or contaminants such as wood, clay, metal, plastics, wet cement, textiles, asbestos, tarmac, etc.

Subject to the function and conditions of use stated, the 4000 series should be capable of handling the following;

1. Mineral crush typically found within recycling and demolition areas.
2. Materials typically pre-formed such as brick and composite base.
3. Materials also shaped from mineral solids such as stone and block work.



## **CONDITIONS OF USE: (for standard units) \*\***

The 4000 series compact crusher is designed for use only in the following conditions:

Temperature: Do not operate the crusher in temperatures below minus 5°Centigrade or above plus 30°Centigrade.

Environment: the crusher is designed for use outside only, in normal humidity conditions only.

Platform: firm, level ground only.

Personnel: only to be used by trained personnel.

Atmosphere: operate only in clean, unpolluted air, and do not operate in excessive wind speeds, or abnormal altitude.

Duration: maximum 12 hours operation in any 15-hour period

Operation: use only with correct loading methods and with correct loading equipment (not exceeding 7t excavator or equivalent), as detailed in the Operation Manual.

Maintenance: use only if serviced in accordance with the service and maintenance schedules outlined in the Operation Manual, utilizing only genuine parts and lubricants.

Transportation: for use only in accordance with all applicable legal transportation restrictions. Legislation: for use only in accordance with all relevant and applicable legislation and regulations. \*\*

\*\* Please refer to the engine manual supplied for the restrictions imposed upon the engine for the limitations of the environment (temperature, altitude, humidity, etc) in which the engine can be operated.

## **Warranty Audits and Surveys**

Red Rhino Crushers (UK) Ltd reserves the right to carry out audits and inspections from time to time in relation to any reimbursed or outstanding warranty claims in order to determine that all relevant details and information is correct.

## **Service & Warranty Training**

Service & Warranty training for service fitters can be requested in writing to [service@redrhinocrushers.net](mailto:service@redrhinocrushers.net)

Initial training will be carried out at an appropriate Red Rhino Crushers (UK) Ltd workshop. Once this initial training has been carried out, you are responsible to carry out further training as required by your own service centre, and to record service actions in accordance with Red Rhino Crushers (UK) Ltd service record documentation.

## **Service Bulletins**

Red Rhino Crushers (UK) Ltd may from time to time issue service bulletins to keep you up to date as to any developments or changes that take place on the complete assembly or component parts.

# Warranty Registration and Installation Certificate

## Warranty Claim Procedure(s):

### Installation:

It is mandatory that the Warranty Registration and Installation Certificates are completed, signed and returned by the original purchaser to Red Rhino Crushers (UK) Ltd. This is essential for the Red Rhino Warranty Registration & Installation Certificate, and Kubota engine manufacturers Warranty Certificate. Warranty commences from date of collection from our premises.

### Terms:

Red Rhino products are warranted against defect in material and workmanship for a period of 12 months or 1000 working hours from the date of installation, whichever occurs first. Two years on the engine.

### Warranty Claim Submission Procedure:

The warranty liability is limited to diagnosis, repair or replacement of the defective part. Depending on the product terms and conditions, and subject to the above, Red Rhino Crushers (UK) Ltd may actuate the repair or provide compensation in the form of a credit note only, for labour incurred in actuating the repair. In all cases, a credit note for labour will only be provided for the replacement or repair of the defective part(s) and in accordance with the time allowances detailed in the Red Rhino workshop manual, and limited in all cases to the standard hourly rate mentioned above

### Claims must be reported accurately, and all relevant details given, as follows:

- OWNERS NAME AND ADDRESS: full name and address of customer and site location if different
- SERIAL NUMBER:
- MACHINE TYPE: state machine type
- DATE OF PURCHASE:
- DATE OF DELIVERY/COLLECTION: ENGINE NUMBER:
- HOURS USED: DATE OF FAILURE:
- CUSTOMER PURCHASE ORDER NUMBER: (This must be supplied)
- RED RHINO CRUSHERS (UK) LTD REF. NO.: (This must be quoted)

**Please contact Red Rhino for a Claim Form.**

## Warranty Registration and Installation Certificate

MODEL: \_\_\_\_\_

SPECIFICATION: \_\_\_\_\_

SERIAL NUMBER: \_\_\_\_\_

DELIVERY DATE: \_\_\_\_\_

I confirm that I have been instructed on the safe use of the Red Rhino Crusher or Screener as detailed above, and that I have retained and read a copy of the operator instruction manual in full and that I understand the terms of the warranty.

Purchased From: \_\_\_\_\_

Date: \_\_\_\_\_

Name: \_\_\_\_\_

Signed: \_\_\_\_\_

Position: \_\_\_\_\_

Company Address \_\_\_\_\_

\_\_\_\_\_

\_\_\_\_\_

\_\_\_\_\_

\_\_\_\_\_

Tel: \_\_\_\_\_

Email: \_\_\_\_\_

Web: \_\_\_\_\_

**IT IS ESSENTIAL TO RETURN THIS FORM TO ACTIVATE AND REGISTER YOUR WARRANTY. FAILURE TO RETURN ANY OF THE WARRANTY REGISTRATION FORMS WILL INVALIDATE WARRANTY.**

**(See " Contents" page).**

**Please complete the following form to register your warranty and post to:**

Red Rhino Crushers (UK) Ltd  
Isaac Newton Way  
Alma Park Road  
Grantham  
Lincolnshire  
NG31 9RT  
United Kingdom



## EU Declaration of Conformity

We hereby certify that the machinery detailed below complies with all the relevant provisions of the EC Machinery Directive as amended and the National Laws and Regulations adopting this Directive.

**Machine Description:** Track mounted compact diesel/hydraulic powered jaw crusher for recycling all types of aggregate based building materials.

**MAKE:** Red Rhino Crusher

**MODEL:** 4000 Series

**SERIAL NUMBER:** \_\_\_\_\_

**ENGINE NUMBER:** \_\_\_\_\_

**NAME of MANUFACTURER:**

Red Rhino Crushers (UK) Limited  
Isaac Newton Way  
Alma Park Road,  
Grantham,  
Lincolnshire,  
NG31 9RT,  
United Kingdom.  
T: +44 (0) 1476 590 790  
E: [info@redrhinocrushers.net](mailto:info@redrhinocrushers.net)  
W: [www.redrhinocrushers.com](http://www.redrhinocrushers.com)

Conforms to the Machinery Directive; 2006/42/EC and amended directive 95/16/EC (re-cast).

Conforms to Electromagnetic Compatibility Directive (EMC); 2004/108/EC

Conforms to Radio Equipment Directive (RED); 2014/53/EC

It also complies with the Essential Health and Safety Requirements (EHSR), national standards and transposed harmonized standards appropriate for this product type.

BS ISO 21873: 2009 Building Construction Machinery and Equipment- Mobile

BS EN1009: Machines for mechanical processing of minerals and similar solid materials.

Crushers, parts 1 & 2

**SIGNED:**  .....

**DATE:** .....

**NAME:** Andrew Hall

**POSITION:** Operations Manager – *(Being the responsible person appointed by the Manufacturer.)*



# Red Rhino Crushers (UK) Ltd



## Declaration of Conformity

In accordance with UK Government Guidance

### Product Model/Type

Product Red Rhino  
 Model 4000  
 Serial Number 4011065

### Manufacturer

Red Rhino Crushers (UK) Ltd

### Address

Isaac Newton Way, Alma Park Industrial Estate, Grantham, Lincs, NG31 9RT

This declaration is issued under the sole responsibility of the product manufacturer.

The object of the declaration described above is in conformity with the relevant UK Statutory Instruments and their amendments.

We hereby declare that the product described above, to which this declaration of conformity refers to, is in conformity with the essential requirements of the following standards.

Reference & Date
Conforms to the Machinery Directive 2006/42/EC and amended directive 95/16/E
Conforms to Electromagnetic Compatibility Directive (EMC) 2004/108/EC
Conforms to Radio Equipment Directive (RED) 2014/53/EC
It also complies with the Essential Health and Safety Requirements (EHSR), national standards and transposed harmonized standards appropriate for this type
BS ISO 21873 2009 Building Construction Machinery and Equipment Mobile
BS EN1009 Machines for mechanical processing of minerals and similar solid materials

Additional Information The technical documentation for the machinery is available from:

Red Rhino Crushers (UK) Ltd

Isaac Newton Way, Alma Park Industrial Estate, Grantham, Lincs, NG31 9RT

Signed for & on behalf of Red Rhino Crushers (UK) Ltd

Place of Issue -----

January 2023

Date of Issue -----

Andrew Hall

Name -----

Operations Manager

Position -----

Signature -----

## Introduction to the Handbook

This handbook covers the following models in the Red Rhino Crusher range:

### 4000 Series

The above machine is designed primarily for the crushing of waste construction material and aggregate for recycling purposes or ease of transportation

Modifications or alterations to the machine are strictly forbidden without the prior written consent of Red Rhino Crushers (UK) LTD.

If the machine is used in any way contrary to its intended use, or if the machine is modified or altered in any way without the prior written consent of Red Rhino Crushers (UK) LTD, or if the machine is incorrectly or recklessly driven, operated or maintained, Red Rhino Crushers (UK) LTD will not accept any liability whatsoever for any damage or injury (whether direct or consequential).

The methods of Operation & Maintenance specified in this handbook should be strictly adhered to. For your parts requirements it is essential that only Red Rhino Crushers (UK) LTD genuine parts are fitted. Any damage resulting from the fitment of non-genuine parts will invalidate the machine warranty. The content of this handbook whilst correct at the time of publication may be subject to alteration by the company at any time without notice.

Red Rhino Crushers (UK) LTD operates a policy of continuous improvement and reserve the right to change specification and equipment without notice. Therefore, some illustrations and accompanying text may differ slightly from your machine.

References to Left or Right contained in this handbook are as seen from the rear of machine forward.



## Introduction to the Handbook

The contents of the Operators Handbook are intended as a guide to the operation and servicing of the *4000 Series*.

The general method of operation of all these machines is the same. Any individual differences in the specification or operation are detailed separately.

**This handbook is not a training manual.** It is designed as a guide to the machine's controls and working capacities and general maintenance only. It must not be removed from the machine and should be kept clean and in good condition.

Additional copies of the handbook can be obtained from Red Rhino Crushers (UK) LTD.

**Only trained operators should use this machine.** Red Rhino Crushers (UK) LTD strongly recommend that anyone who is responsible for the operation and servicing of this machine be fully trained & competent operator.

If you have any doubts about any aspects of the machine's capability or servicing procedures, you must consult Red Rhino Crushers (UK) LTD.

Throughout this handbook and on the machine, there are safety notes. Each note starts with a single word.

The meaning of these single words are explained below.



### **Safety Warnings**

This safety alert system identifies important safety messages in this manual. When you see this symbol, be alert, your safety is involved, carefully read the message that follows, and inform other operators.

In this publication and on the machine, there are safety notices; each notice starts with a signal word meaning are provided below.



### **Danger**

Denotes an extreme hazard exists. If proper precautions are not taken, it is highly probable that the operator (or others) could be killed or seriously injured.



### **Warning**

Denotes a hazard exists. If proper precautions are not taken, the operator (or others) could be killed or seriously injured.



### **Caution**

Denotes a reminder of safety practices could result in injury to the operator (or others) and possible damage to the machine.

In general, these notes are used to indicate that the procedures being described in the Handbook must be followed to avoid serious injury or death to yourself or others. The notes are also used to protect the machine from unsafe servicing practices.

These notes do not replace safety codes, insurance requirements & local laws. Make sure the machine has the correct equipment to comply with local regulations.

Pay particular attention to the safety notes given throughout the handbook.

It is the responsibility of the Operator to fully read all of the handbook & understand it before attempting to operate the machine.

# Warning Labels & Symbols Found on the Red Rhino 4000



Emergency Stop



Read Operation Manual



Tie Down Points



Wear protective Clothing



Danger of trapping

## Stopping the Machine in an Emergency



### Warning

The machine can be stopped in an emergency by pressing the emergency stop buttons located along each side of the machine or by turning the ignition key directly to the “off” position.

Make sure that all persons in the area of the machine are fully trained in the location of the emergency stops and how to use them.

Emergency stop switches can be located on front and rear of the feed hopper. In the case of an emergency press one of these switches to disengage the engine and stop the crusher.

Ensure the Hazard is corrected before re-starting the engine.

In an emergency shut down the crusher. This will normally be full of material it is possible to restart the crusher whilst full but you should read and follow the instructions below.

Return all controls to neutral.

Rotate the emergency button until it is released.

Return the key to the “OFF” position. The engine will not start until this has been done.

Restart by turning key to “ON”, then “START”.

Start the conveyor first, followed by the crusher.

*NOTE: If the crusher does not operate immediately you MUST run the crusher in reverse for 10 seconds in order to release material caught in the crusher jaws, and it may be necessary to do this several times in order to ensure the machine is running correctly.*

Adjust engine speed as necessary.

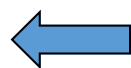
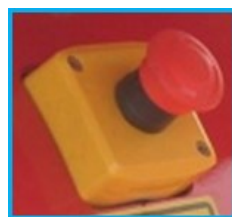

**REAR OF  
MACHINE**



**FRONT OF  
MACHINE**



# Component Locations

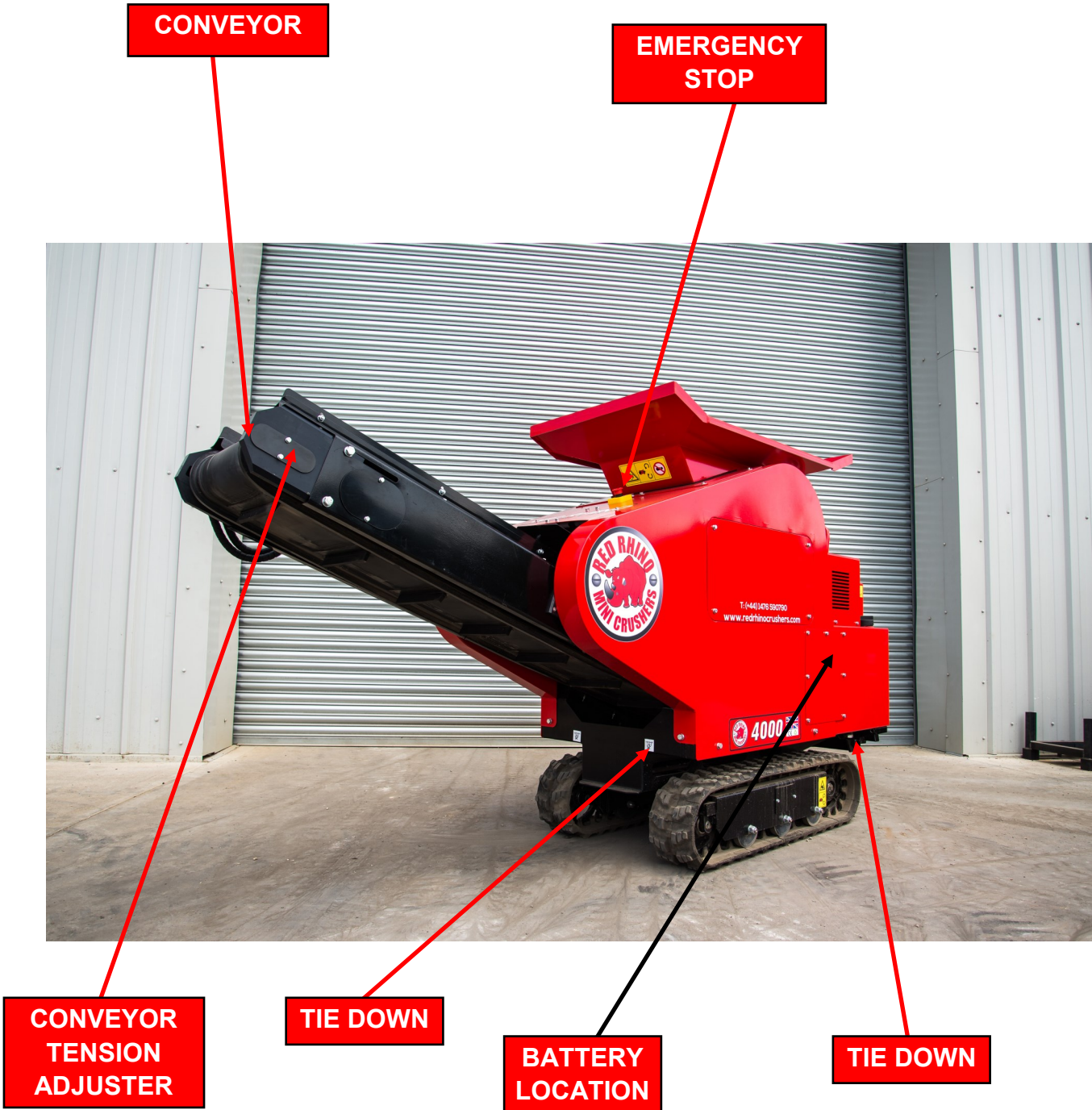



# Component Locations

HYDRAULIC CONTROLS

FEEDER HOPPER



FUEL LEVEL

OPERATOR PLATFORM

HYDRAULIC LEVER

THROTTLE LEVER

START PANEL

RUNNING TRACKS



## General Safety



### **Warning**

To operate the machine safely you must know the machine and have the skills to use it. You must abide by all relevant laws, health and safety regulations that apply to the country you are operating in.

The operator manual instructs you on the machine, its controls and its safe operation.



### **Warning**

You and others could be killed or seriously injured if you operate or maintain the machine without first studying the operator manual. You must understand and follow the instructions in the operator manual. If you do not understand anything, ask your employer or Red Rhino dealer to explain it.



### **Warning**

#### **Care and alertness:**

All the time you

- Are working with or on the machine, take care and stay alert.
- Always be careful.
- Always be alert for hazards.



### **Warning**

#### **Clothing:**

- You can be injured if you do not wear the proper clothing. Loose clothing can get caught in the machinery.
- Wear protective clothing to suit the job. Examples of protective clothing are: a hard hat, safety shoes, safety glasses, a well-fitting overall, ear-protectors and industrial gloves.
- Keep cuffs fastened.
- Do not wear a necktie or scarf.
- Keep long hair restrained.
- Remove rings, watches and personal jewellery.



### **Warning**

#### **Alcohol and drugs:**

- It is extremely dangerous to operate machinery when under the influence of alcohol or drugs.
- Do not consume alcoholic drinks or take drugs before or while operating the machine.
- Be aware of medicines which can cause drowsiness.



### **Warning**

#### **Feeling unwell:**

Do not attempt to operate the machine if you are feeling unwell. By doing so you could be a danger to yourself and those you work with.



### **Warning**

#### **Mobile Phones:**

- Switch off your mobile phone before entering an area with a potentially explosive atmosphere; Sparks in such an area could cause an explosion or fire resulting in death or serious injury.
- Switch off and do not use your mobile phone when refuelling the machine.



### **Warning**

#### **Raised Machine:**

- Never position yourself or any part of your body under a raised machine which is not properly supported; if the machine moves you could become trapped and suffer serious injury or be killed.



### **Warning**

#### **Machine Modifications:**

- This machine is manufactured in compliance with legislative and other requirements. It should not be altered in any way which could affect or invalidate any of these requirements.



### **Caution**

#### **Machine Operator:**

This machine must be operated only by correctly trained and authorised personnel. Certain local operating conditions may require the machine operator to obtain an operator's licence or a certificate.



### **Caution**

#### **Magnetic Hazard:**

If this machine is fitted with an over band magnet must not operated by any personal with a pacemaker. Otherwise this could result in death or serious injury.



**Warning**

**Lifting:**

This machine is **NOT** permitted to be lifted for transport or any other reason.



**Warning**

**Power Source:**

Before any maintenance, service or adjustments are carried out on the machine the "POWER SOURCE" must be isolated. Any persons carrying out repairs or maintenance must isolate the machine and remove the ignition control key.

## Operating Safety



### **Warning**

#### **Machine Condition:**

- A defective machine can injure you or others. Do not operate a machine which is defective or has missing parts. Make sure the maintenance procedures in this manual are completed before using the machine.



### **Warning**

#### **Airborne Debris:**

- Airborne articles can be ejected during the crushing process. Erect an exclusion zone with barriers at a safe distance around the machine. Do not let unauthorized people enter the exclusion zone.



### **Warning**

#### **Exhaust:**

- Breathing the machine exhaust gases can harm and possibly kill you. Do not operate the machine in closed spaces without making sure that there is good ventilation. If you begin to feel drowsy, stop the machine and get into fresh air.
- The exhaust pipe becomes extremely hot when the engine is running and will remain so for some time after the engine is stopped; if you touch the hot pipe you could be severely burned.



### **Warning**

#### **Work Site:**

- Work sites can be hazardous. Inspect the site before working on it. You could be killed or injured if the ground gives way under your machine or if piled material collapses on to it. Check for potholes and hidden excavations etc. Any of these could cause you to lose control of your machine.
- Do not work or drive too close to banks and trenches where there is danger of collapse.
- Ensure that you have enough clearance beneath overhead cables and structures.



### **Warning**

#### **Noise:**

- Noise generated by the machine can cause permanent hearing damage over periods of time; hence we strongly recommend all users to wear ear protection at all times.



### **Warning**

#### **Communication:**

- Bad communications can cause accidents. Keep people around you informed of what you will be doing. If you will be working with other people, make sure any hand signals that may be used are understood by everyone.



### **Warning**

#### **Transportation:**

- Make sure that any trailer or vehicle is suitable to transport the machine and meets all road traffic regulations.
- Before moving the machine onto a trailer or vehicle, make sure that load bed and ramps are free from oil, grease, ice and mud.
- Ensure that the ramp angle does not exceed that in the technical details.



### **Warning**

#### **Hazardous Atmospheres:**

- This machine is designed for use in normal outdoor atmospheric conditions. It should not be used in an enclosed area without adequate ventilation.
- Do not use the machine in a potentially explosive atmosphere.



### **Warning**

#### **Moving Components:**

- The machine has rotating parts. Switch OFF the engine before working in the engine compartment.
- Do not use the machine with the engine cover open.



### **Warning**

#### **Machine Safety:**

- Stop work at once if a fault develops. Abnormal sounds and smells can be signs of trouble. Inspect and repair before resuming work.



### **Warning**

#### **Electric Circuits:**

- A competent operator/engineer must first understand the electric circuit before connecting or disconnecting an electrical component
- To avoid injury or damage get the work done by a competent operator/engineer.



**Warning**

**Fire**

Machine fires must not be put out using water. Always use foam, dry chemical or carbon dioxide extinguishers.



## Maintenance Safety



### **Warning**

#### **Repairs:**

- If your machine does not function correctly in any way, get it repaired straight away. Neglect of necessary repairs could result in an accident or affect your health.
- Do not try to do repairs or any other type of maintenance work you do not understand.
- To avoid injury and/or damage get the work done by a competent engineer



### **Warning**

#### **Electric Repairs:**

- Do not try to do repairs or any other type of maintenance work you do not understand.
- To avoid injury and/or damage get the work done by a competent engineer



### **Warning**

#### **Battery:**

- Batteries give off an explosive gas. Do not smoke when handling. Keep away from flames and sparks
- Battery electrolytes contain sulphuric acid; it can burn you if it touches your eyes or skin. Wear goggles and handle carefully to avoid spillages.
- Keep metallic items away from terminals; they can short the terminals and burn you.
- Set all switches to OFF before removing the battery; when removing, remove the earth (-) lead first.
- The battery earth terminal is fitted with a screw-in isolator to facilitate a safe system for working on the crusher.
- Charge the battery away from the machine in a well-ventilated area. Switch off the charging circuit before connecting/ disconnecting the battery.
- When you have installed the battery in the machine, wait five minutes before connecting it up.
- When reconnecting, fit the positive (+) lead first.

### **Battery**

The battery is located behind the left hand side lower inspection panel.

### **Specification**

Model 895, 12 Volt, 26 AH, 250 AMP



# Crushing

All crushing should be done on a level surface.



## Safety Warnings

Crushing machine uses powerful moving jaws so under no circumstances should the machine run without all covers attached or when moving parts are exposed.



## Safety Warnings

Under no circumstances should you attempt to remove blockages by hand.

When the crusher is running you may begin to feed material into the hopper either manually or by machine, ensuring not to overfill the hopper. A steady and constant flow of material will produce maximum crushing efficiency so ensure you take your time to find the best filling procedure.

Once you have finished crushing your material ensure the hopper, crusher box and conveyor are all clear of material then you can stop the crusher simply by returning the switch on the controls to neutral.

## Adjusting Crushers Jaws

Output size of the crushed material may be varied by reducing or increasing the jaw spacing suitably.



## Safety Warnings

Never attempt to adjust the jaw size of the crusher whilst the crusher is running, or material is still in the crusher; ensure the crusher is both clear and not running before attempting to adjust otherwise you will risk damage to your crusher.

The crushing jaw can be adjusted hydraulically using the touch panel or on the remote handset. Once adjusted be sure to attempt a small amount of material to determine if the output size meets your requirements.

## Excavator Specification Advised

Maximum Bucket Capacity	Excavator	Loading Position
18 inches / 457.2mm	3 Tonne	Side hopper left hand or right hand loading

## Crushing Materials

### Suitable Materials for Crushing

Possible crushing materials include stones, rocks, bricks, concrete, kerb stones and general construction rubble.

It may be possible to also crush steel reinforced concrete though you should first consult your Red Rhino dealer in order to determine if your machine is capable.

If unsure of a material for crushing consult your Red Rhino dealer for information.

### Unsuitable Materials for Crushing

The machine will not crush wood, plastic, fresh blacktop (tarmac), clay or wet mud. Whilst these items will not damage your crusher jaws, they will contaminate your reusable aggregates, cause blockages and reduce crushing time.

The conveyor belt is a consumable item, and as such is not covered by warranty. You should avoid any metal/ steel items entering your crusher. These items will damage the conveyor belt.

It is advisable to inspect the stockpile from time to time and remove any of the above items manually.

Material which is longer than 380mm will need to be fed into the jaws lengthways – material which is wider than 215mm will be too wide for the maximum jaws setting.



### **Caution**

Attempting to crush any of these materials will put you under serious danger and risk of serious if not fatal injury.

### Unblocking Crusher Jaws

In the event the crusher becomes blocked or material is failing to pass through the crushing jaws; under no circumstances should you attempt to enter or reach into the crusher.

The jaw adjustment feature, via manual control lever can be utilized to open the jaws and release blocked/ bridged material. Never close-up the jaws unless the jaws are completely empty.

Similarly bridges/blockages can be freed by reversing the direction of the jaw plates using the reverse option on the crusher controls lever. Do not attempt to change the crusher direction until the crusher has come to a complete stop.

# Operation Instructions

## Gradient

### Transportation

When loading the Machine for transport, the ramp must **NOT** exceed 20°. It should also be noted that ground conditions should be taken into consideration as to whether the conditions are wet or slippery because this will greatly reduce this value.

### Travelling

When moving the machine slope of the ground should **NOT** exceed 15°. It should also be noted that ground conditions should be taken into consideration as to whether the conditions are wet or slippery because this will greatly reduce this value.

### Tie Down



The tie down points can be found on the front and back on both sides of the crusher. The tie down points should be used to secure the machine for transportation.

A securing additional strap over the top of the hopper and tied down is also recommended.



### **Safety Warnings**

The tie down points should never be used to lift or tow the machine.

## Pre-Start Safety Checks

The following checks must be carried out prior to commencing work. Particular attention must be given if the machine has been left idle for any period of time. All of these checks concern the continued operation of the machine and some concern your safety. Any defects should be inspected and corrected by your distributor or service engineer.



### **Warning**

***NEVER*** commence work with the machine until a full pre-start safety check has been carried out.



### **Warning**

Only trained competent operators must operate this machine.

1. Check the engine oil level
2. Check the hydraulic oil level
3. Check the fuel level
4. Check the coolant level
5. Turn ignition on and ensure no malfunction errors are shown
6. Check that no one is within 15 metres of the machine
7. Proceed to start

For further Technical Information please refer to the Kubota Engine Operators Manual.

## Guidance to Machine Pre-Start Checks



Engine Oil Dipstick is located through the top inspection panel at the rear of the crusher.



Hydraulic oil level is located on the right hand rear side of the machine.

Hydraulic Oil capacity 33 litres.

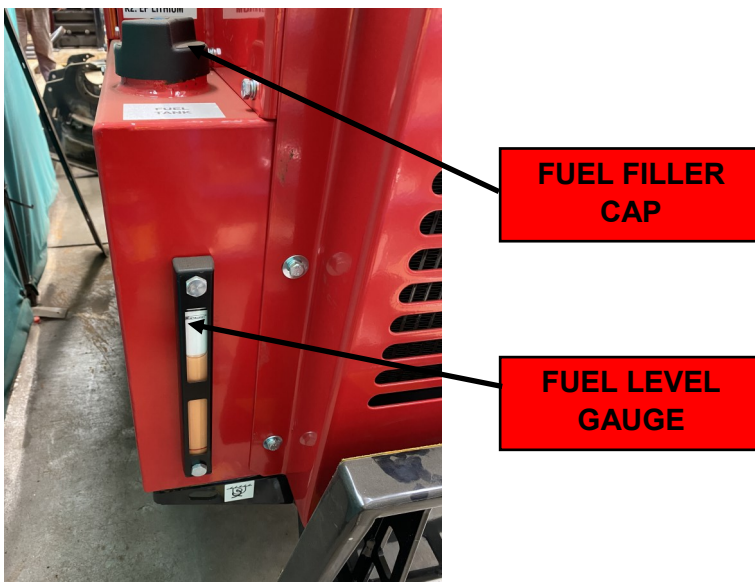

The Fuel level gauge is located on the left hand rear side of the machine.

Fuel Capacity 25 litres.





**RADIATOR  
COOLANT  
LEVEL  
BOTTLE**



**RADIATOR  
INSPECTION  
COOLANT**

**Inside the rear top inspection panel the water coolant level tank is located. The water level should remain between MIN—MAX.**



**IGNITION  
CONTROL  
PANEL**

**Ignition control panel located on the right hand rear of the machine.**

# Engine Controls

## Control Panel











The Ignition Control Panel and the Engine Throttle lever are located at the rear right hand side of the machine.

## Ignition Control

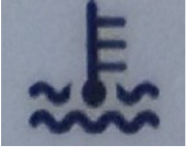

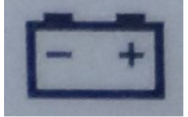
## Indication Lights

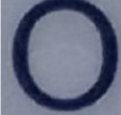
<p><b><u>Engine Overspeed Indication</u></b></p> <p>Not applicable on this machine.</p>			<p><b><u>Keyswitch Ignition</u></b></p> <p>Operated by key to start / stop the</p>
<p><b><u>Input Active</u></b></p> <p>Not applicable on this machine.</p>			<p><b><u>Starting: On</u></b></p> <p>When key is turned to start position; the battery is connected to the</p>
<p><b><u>Engine Temperature Indicator</u></b></p> <p>When illuminated the engine temperature is too high; cooling fan belt is slipping / broken or the</p>			<p><b><u>Pre-Heat</u></b></p> <p>Press and hold this button to pre-heat engine.</p>
<p><b><u>Charge Indicator</u></b></p> <p>Indicates alternator status, illu-</p>			<p><b><u>Start</u></b></p> <p>Press to start engine.</p>
<p><b><u>Engine Oil Pressure Indicator</u></b></p> <p>When illuminated the engine oil pressure is too low.</p>			<p><b><u>Off / Stop Engine</u></b></p> <p>Turn the key to this position to stop the engine.</p>

## Hours Run Counter

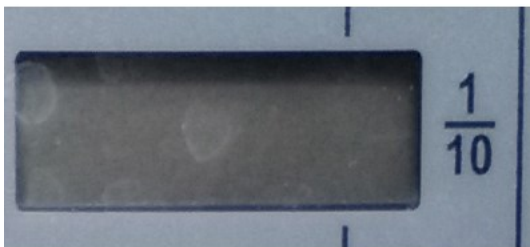

Records the total running time of the engine.



# Discharge Conveyor

## Starting the Conveyor system

Before attempting to crush any material, you should first ensure that the conveyor is running so there will not be a build-up on material in the crusher.

The conveyor is started by using the touch pad on the remote control, when using the radio remote control the conveyor will stop after 30 seconds if the remote signal is lost.



### Safety Warnings

Do not place hands near conveyor whilst in operation; conveyor belt can cause injury whilst running if due care and attention is not taken.



### Danger

It is against the law to crush any materials deemed flammable, explosive, or toxic. It is also against the law to crush asbestos. DO NOT attempt to crush metals.

## Conveyor Belt

### Checking the condition of the conveyor belt:

The conveyor belt should be checked for any cuts or wear that may indicate it needs to be replaced.

### Checking and adjusting the conveyor belt:

Check the conveyor belt in operation. The belt should be inspected visually to ensure there is no slippage on the rollers and the belt is running true. Should the belt require tightening, at the end of the conveyor, there are tension adjusters on the left hand and right-hand sides.

Note: The belt should be tightened carefully to ensure both sides are adjusted equally so the conveyor will still run true, also the belt should not be over tightened and given around 50mm slack at the centre of the belt beneath the conveyor.



**CONVEYOR BELT  
TENSION ADJUSTERS**

### Belt Scraper

Inside the conveyor section there is a belt scraper on the inside circumference of the belt. The scraper acts as a fines cleaner to prevent build up around the Drive and Tail drum. The scraper should periodically be inspected, adjusted to run lightly on the belt and debris build up should be removed.



**BELT SCRAPER ON  
UNDERSIDE OF BELT  
RETURN**

## Dust Suppression

Above the conveyor discharge belt a dust suppression water spray bar is mounted. This is a cross belt assembly fitted with three water nozzle jet valves.



A mains water supply is required to connect to the spray bar. This connection point is on the left hand side of the machine.



## Running Gear (Rubber Tracks)

### Checking tracks for cuts and abrasions:

Whilst visually inspecting the tracks, attention should also be taken for any signs of wear on the tracks such as damage that may indicate the tracks need to be replaced.

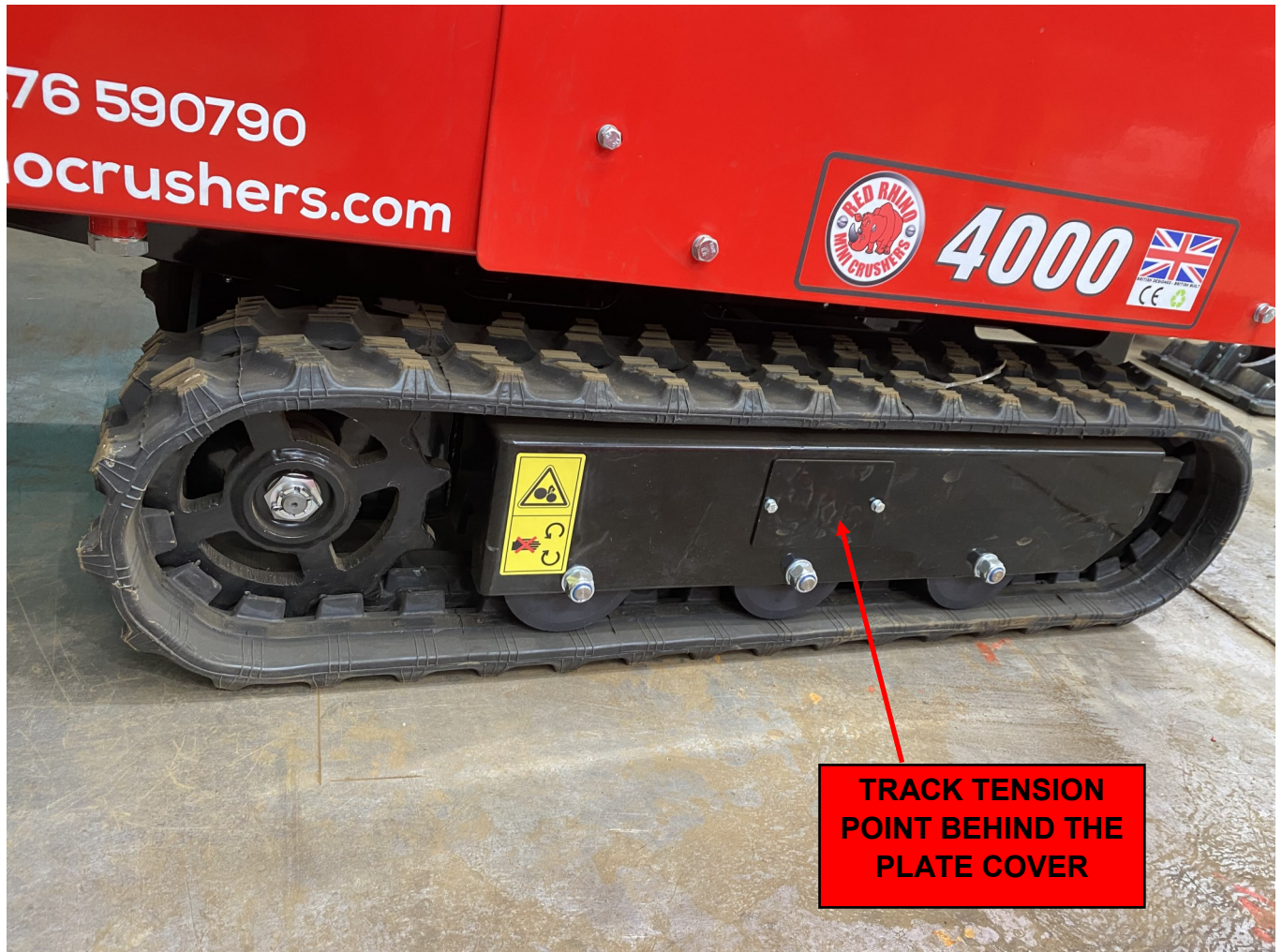



## Track Adjustment

### Track Adjustment Settings

In order to establish if the track requires tensioning move the Host machine a few metres forwards and backwards on level ground. This allows the tracks to adopt their natural degree of tension

#### Note: Do not slew the machine

Using a straight edge and a tape measure, measure the droop of the Track Group. For this particular Track Set, the droop should not exceed 20mm.

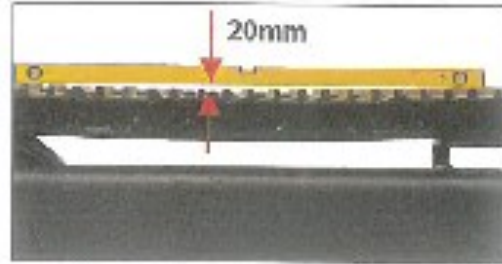

**Note: It is also important that the Track is not tensioned too tightly as this places excessive loads on the Gearbox and Idler bearings. It will also lead to accelerated wear and premature failures.**

After maintenance or overtime the tracks may become slack and will have to be adjusted back to tension.

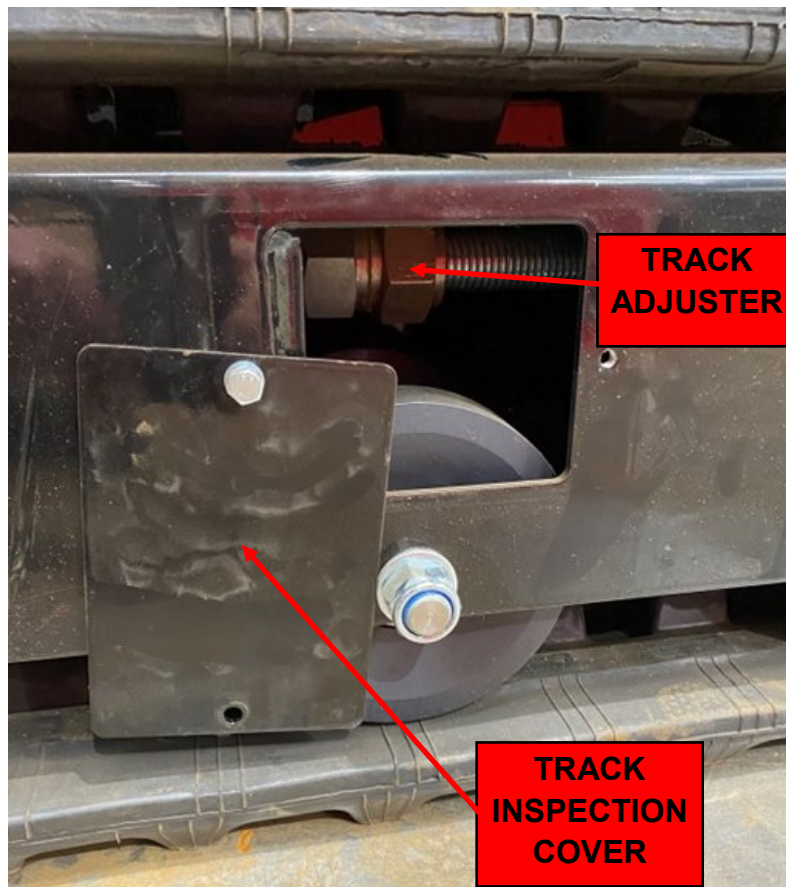

To gain access to the Track Adjustment remove the inspection cover on the side of the track body. The Track Adjustment is a manual mechanical adjuster. This adjuster screw should be turned to tighten or release the track tension.

## Jaw Crusher Unit

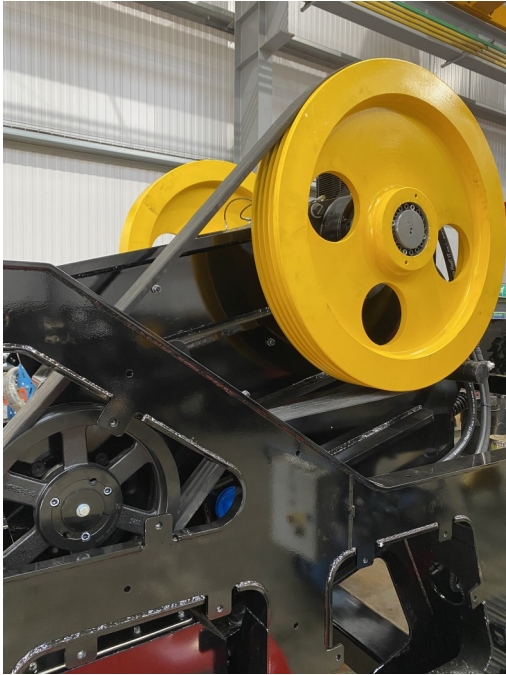

The Jaw Crusher Unit is an integral part of the crusher and is situated centrally within the chassis.

The Crusher is hydraulically driven via flywheels, belt and tensioner to give the crusher reciprocating motion.



### JAW PLATES

The Crusher unit consists of fixed and moving jaw wear plates. These are a wearing part which will need replacing after time and can be reversed for maximum use.



### Warning Danger

The Jaw Plates are loose when securing wedge and bolts the nuts are not installed and tightened and the jaw plate could fall and cause a serious injury, death or damage the equipment. Make sure it is held in position when the lifting tools are removed. Make sure persons are **NEVER** in the jaw box or between the jaw plates.





Hydraulic rams are operated from the remote control. This operates a wedge system to narrow or widen the bottom opening of the jaw. This adjustment allows the sizing of the discharge crushed material.

The Crusher Box has a central greasing point for the inner and outer bearings, situated on the rear left hand side of the machine. Recommend greasing every 250 hours.



### CRUSHER TOGGLE PLATE

This protects the Crusher from loads generated by uncrushable objects.

The “Toggle Plate” is a protection device and will collapse or bend when crushing loads are exceeded.

The Toggle Plate is a replacement spare part.

To inspect the crusher drive belt and tension arm remove the left hand side inspection panel. This will give full access to the crusher drive assembly.



## Guide to Servicing Your Machine



### Warning

All service work should be carried out by qualified and competent personnel. The crusher should be on solid, level ground and both ignition and battery isolator keys removed with battery disconnected.

For access to service components, the following guards should be removed:

- Top Engine Inspection Panels
- Rear Radiator Cover Panel
- Left Hand Lower Inspection Panel

FOR FULL ENGINE SERVICE DETAILS REFER TO THE [KUBOTA ENGINE MANUAL](#).

**FOR SERVICE AND TECHNICAL ASSISTANCE PLEASE CONTACT:**

RED RHINO SERVICE DEPARTMENT EMAIL: [service@redhincrushers.net](mailto:service@redhincrushers.net)

TELEPHONE: +44 (0) 1476 590790





## Engine Service

### Engine Oil Dipstick

Accessible through the top engine inspection panel.

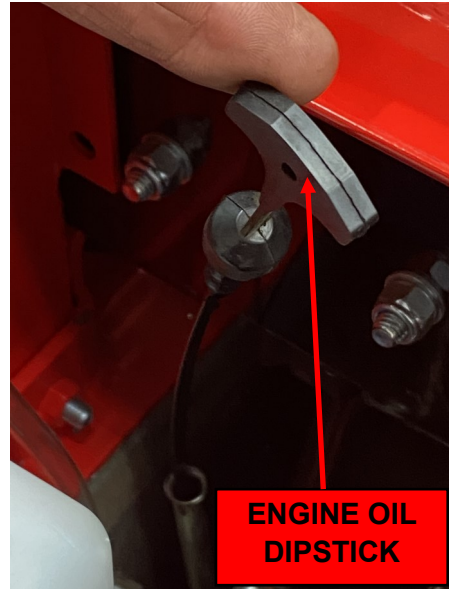

### Engine Oil Filter

Accessible through the rear radiator cover panel on the right hand side of the engine.

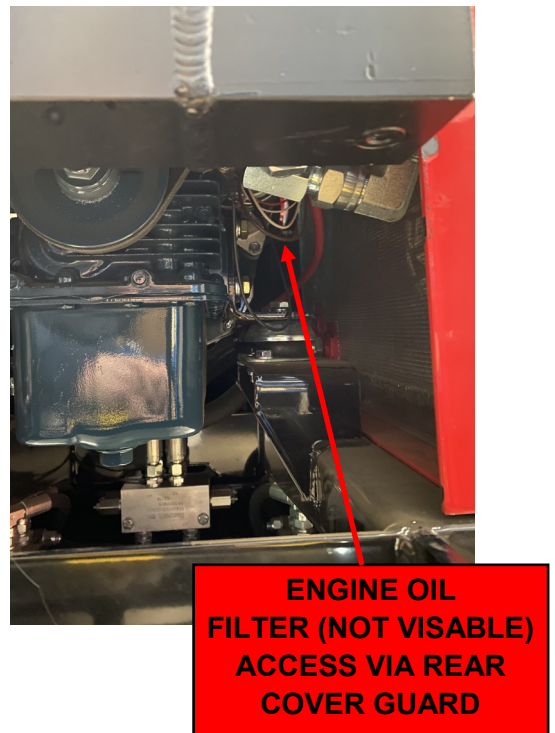

### **Engine Oil Drain Plug**

Accessible from beneath the engine under the machine.

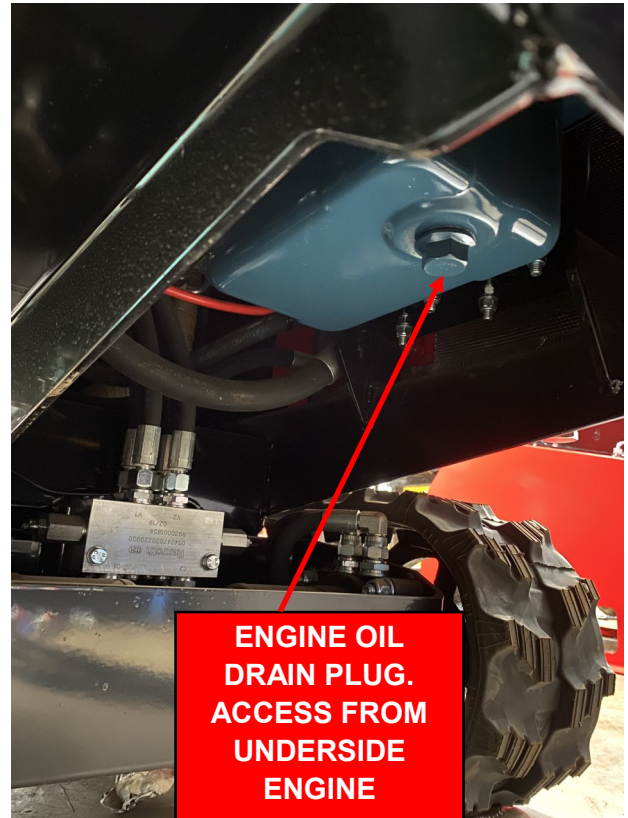

### **Engine Oil Filler Cap**

Accessible through the top engine inspection panel.

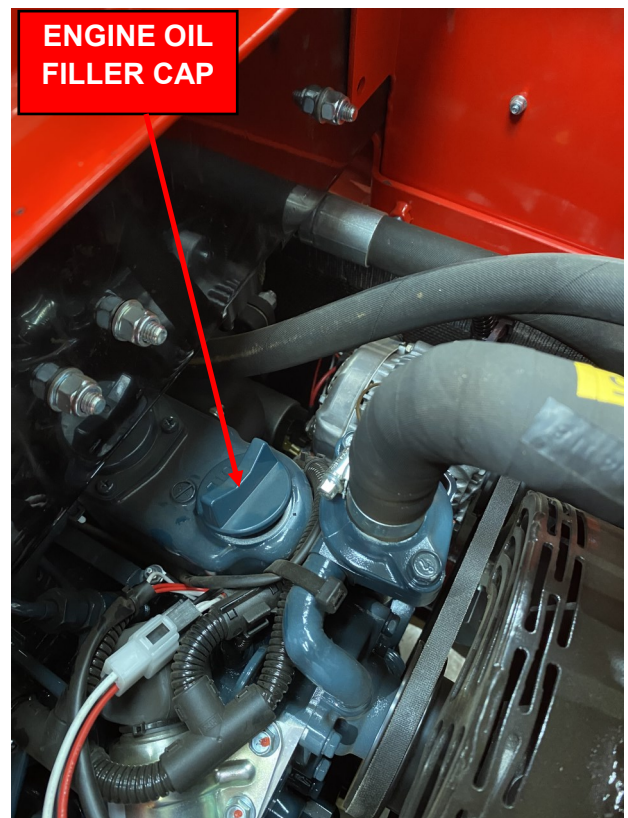

**ENGINE OIL GRADE SAE 10W-40**  
**ENGINE OIL CAPACITY 2.6 LITRES**



## **AIR FILTRATION**

The Air Filter Element is accessible via the left hand side inspection panel. Remove the Filter End Cap and pull out the Air Filter Element.

**INSPECT REGULARLY** (Knock out dust contamination)

**REPLACE**—Refer to the Kubota Engine Manual.

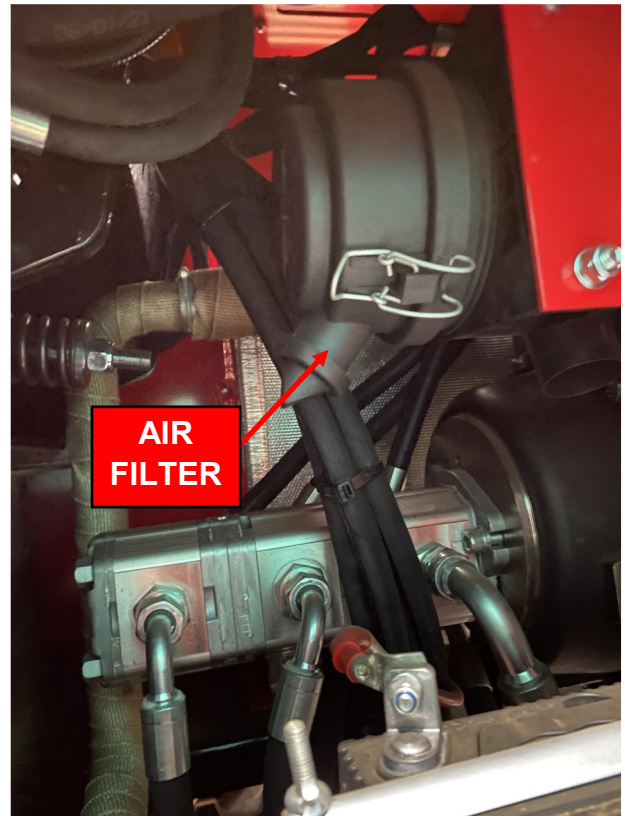

## **FUEL SYSTEM**

The fuel filter is located via the rear radiator inspection cover.

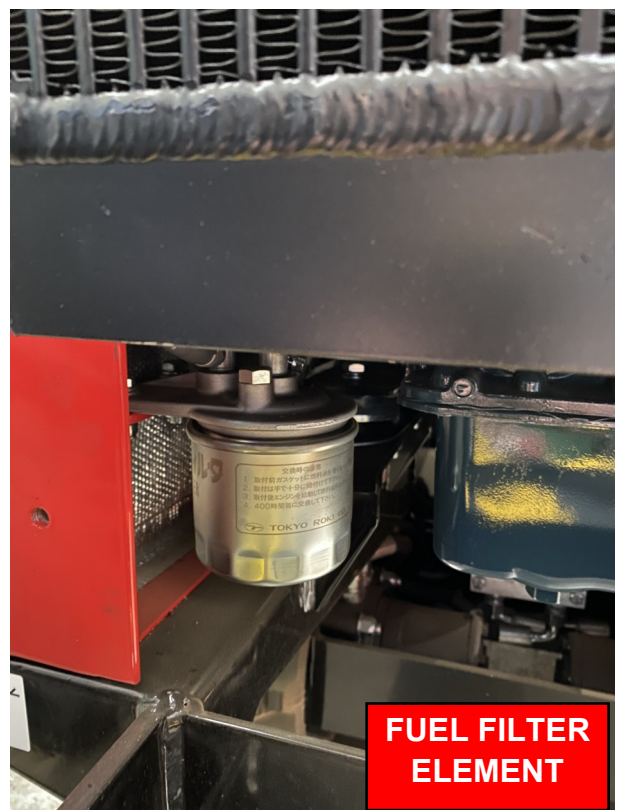

## COOLING SYSTEM

The radiator cooling system is filled with a 50% water, 50% antifreeze mix.

If the water is drained for any reason then the Main Fill is through the Radiator Cap at the rear of the machine.

Inside the engine compartment is a Header Tank Bottle. This is for accurate top up and should be maintained between MAX-MIN Level.



## FAN BELT

The fan belt is accessible through the top engine inspection panel. This should be checked weekly for tension via the Alternator Pulley adjustment.

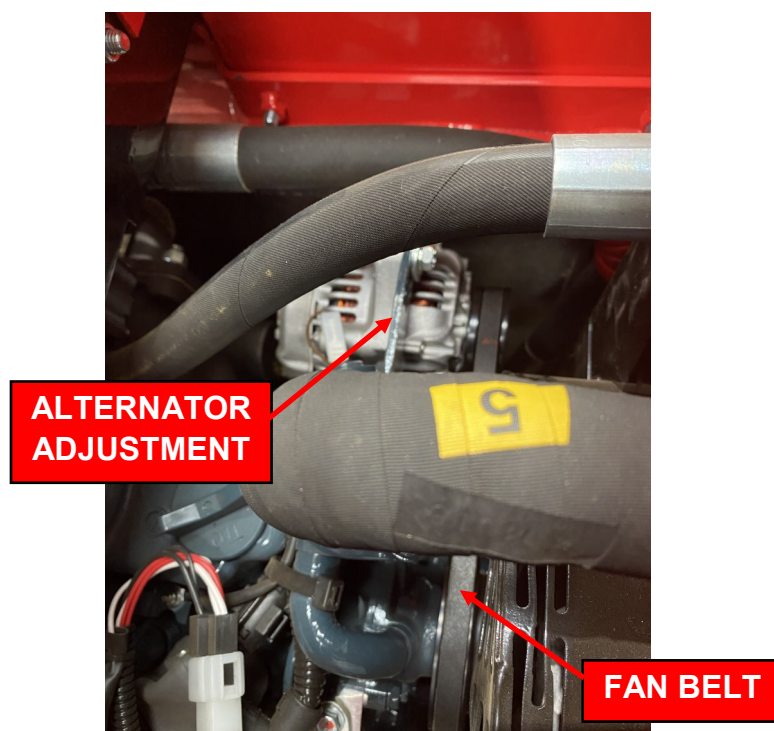



## **HYDRAULICS**

The Hydraulic Oil tank is accessible via the top rear inspection cover.

The hydraulic tank is fitted with a Hydraulic Filter.

To change the filter the cap of the Filter Element should be unscrewed and the element will lift out.

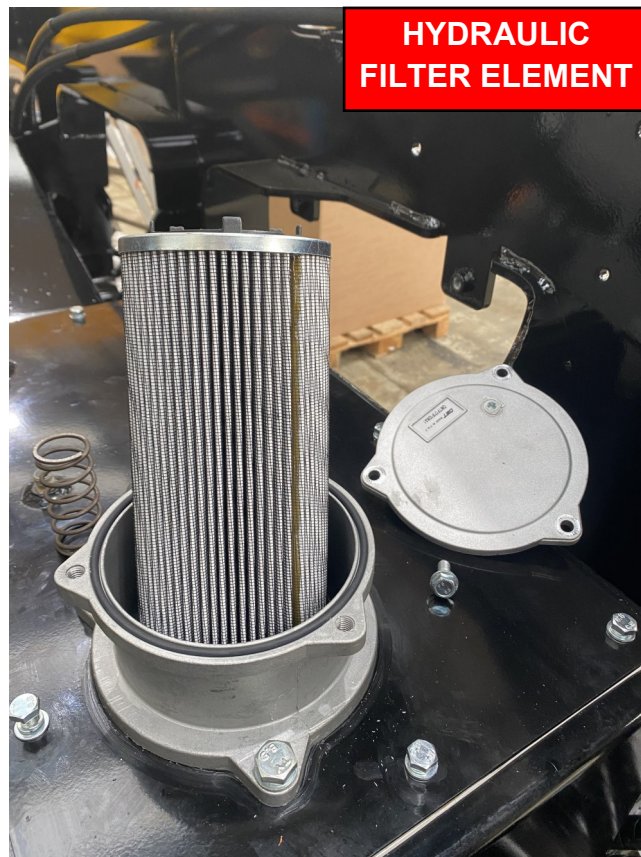

Clean and check the element every 100 hours and replace every 1000 hours.

**HYDRAULIC OIL GRADE SAE: 46 GRADE**

**CAPACITY: 33 LITRES**

## Hydraulic Manual Controls

The Red Rhino 4000 is operated by a manual hydraulic controls. These are operated from the rear of the machine by standing on the fold down platform step. The Hydraulic Levers operate:

- Left hand track
- Right hand track
- Crusher
- Main conveyor
- Jaw size adjustment

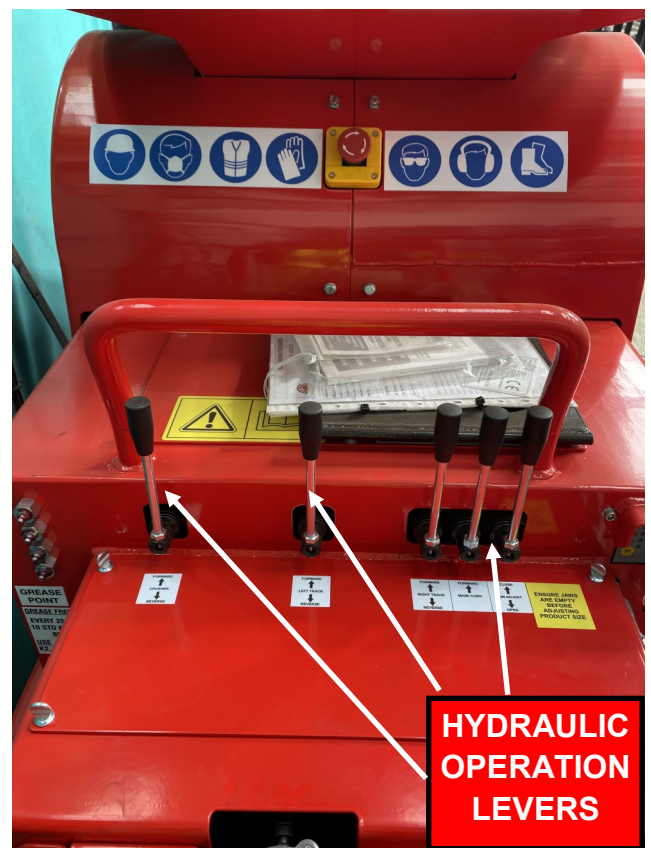

## Deploying Machine into Crushing Operation

- Start the machine and run engine revs at 1/2 throttle for 15 minutes to warm up the hydraulic system.
- Manoeuvre the machine into position ensuring the material to be crushed can be loaded from the side of the machine into the hopper.
- Once you are happy with the machine position, move the throttle lever to **MAX. REVS.**
- Engage the conveyor lever to start the discharge conveyor.
- Engage the crusher lever to start the crusher box.
- The Machine will then be ready for material to be loaded.



## Closing The Machine Down After Crushing Process

- Ensure all crushed material has run out of the Crusher Box and exited the main conveyor.
- Disengage the Crusher Box lever to stop the crusher.
- Disengage the conveyor lever to stop the main conveyor.
- Reduce the engine throttle lever to **MIN. REVS.**
- Turn the engine off at the Ignition Switch.

## Replacement Parts

For replacement parts and / or spares you will need to quote the Red Rhino Model and engine serial number. These are available from the Red Rhino Parts and Service Department. Please email [service@redrhinocrushers.net](mailto:service@redrhinocrushers.net) or call +44 (0) 1476 590790.



## Model Specifications

	<b>Model</b>	<b>4000 (Water Cooled)</b>	
<b>General Data</b>	Prime Mover Type	Internal Combustion Engine	
	Power Installed	10.8kw (14.6hp)	
	Overall dimensions in operating mode	Length	3260mm
		Width	780mm
		Height	1600mm
	Mass in operating mode	1400kg	
	Overall dimensions in transportation mode	Length	3100mm
		Width	780mm
		Height	1600mm
	Mass in transporting mode	1400kg	
	Ground Clearance	230mm	
	Manufacturer	Kubota	
	<b>Detailed Data For Internal Combustion Engine</b>	Model Name	Z602 Stage V emission compliant
		Net Power	10.2kw (14hp)
Rated Revolutions		3200 r/min	
Fuel type		Diesel	
Fuel Tank Capacity		25 liters	
<b>Detailed Data For Feeder Hopper</b>		Type	Fixed
	Size (Charging Width x Charging Length)	710mm x 1260mm	
	Charging Height	1520mm	
<b>Detailed Data For Crushing Device</b>	Type	Hydraulic Jaw	
	Feed opening device	400mm x 170mm	
	Discharge setting range	20mm – 80mm	
	Revolutions Operating	280 rpm	
<b>Detailed Data For Discharge Device</b>	Drive Type	Hydraulic / Mechanical	
	Type	Belt Conveyor	
	Width x Length	538mm x 2190mm	
	Discharge height	1420mm	
<b>Detailed data for Travel device (Crawler Mounted)</b>	Drive type	Hydraulic	
	Track Gauge	570mm	
	Track Shoe Width	180mm	
	Track Length On Ground	940mm	
	Ground Contact Pressure (Average)	19631 Pa (3PSI)	
	Maximum travel speed	1 km/h	
	Drive Type	Hydraulic	
<b>Detailed Data For Tank Capacities</b>	Fuel	25 liters	
	Hydraulic Oil	33 liters	
	Engine Oil	2.6 liters (2.5without filter)	

# General Arrangement Dimension

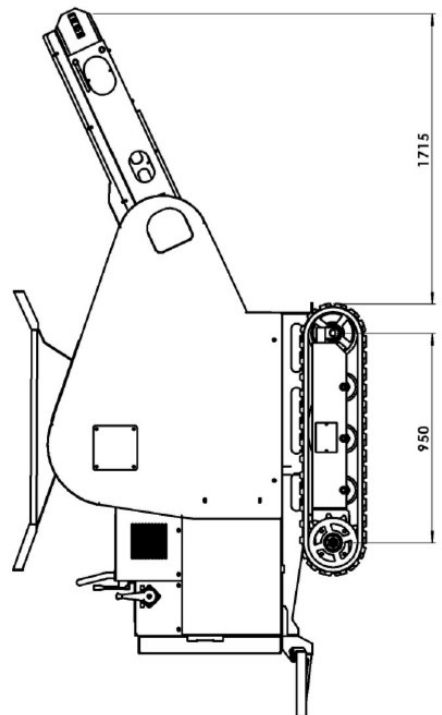
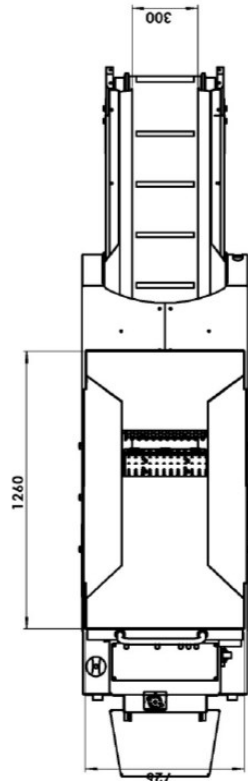
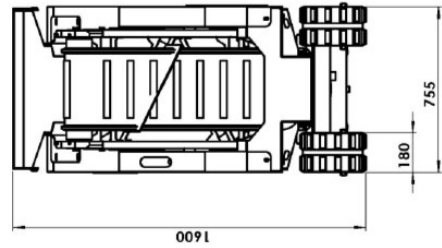
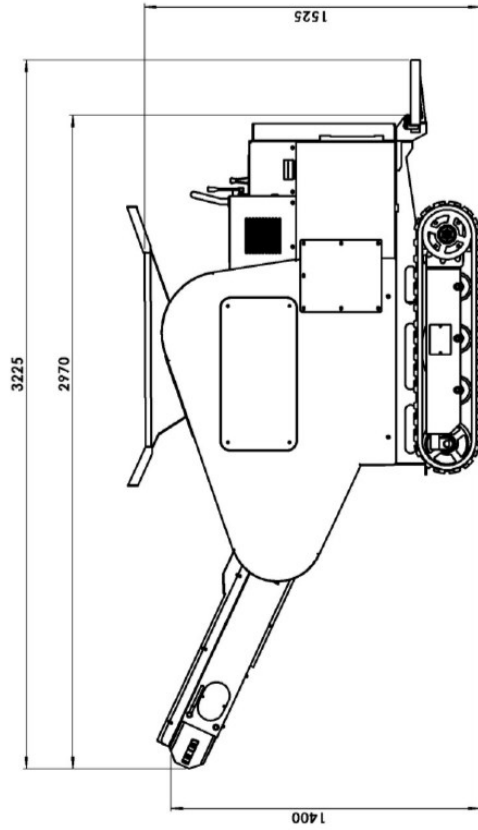
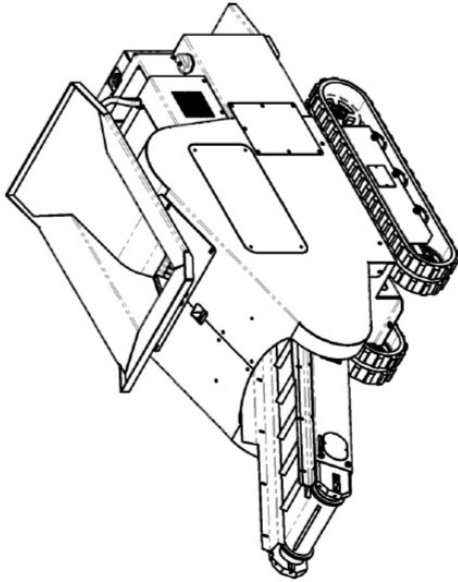

# HYDRAULICS SCHEMATIC

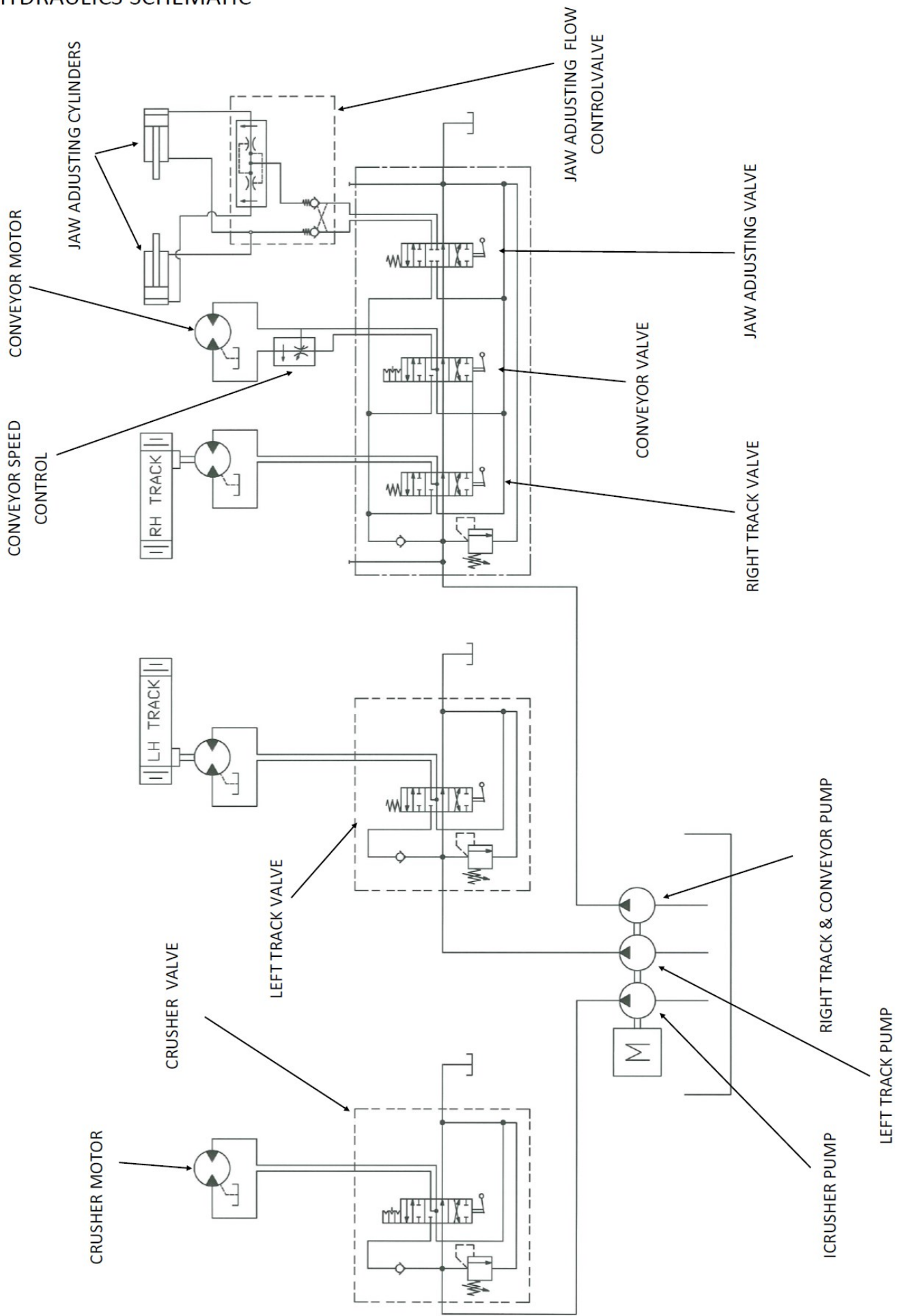



# Electrical Components

## Engine Loom

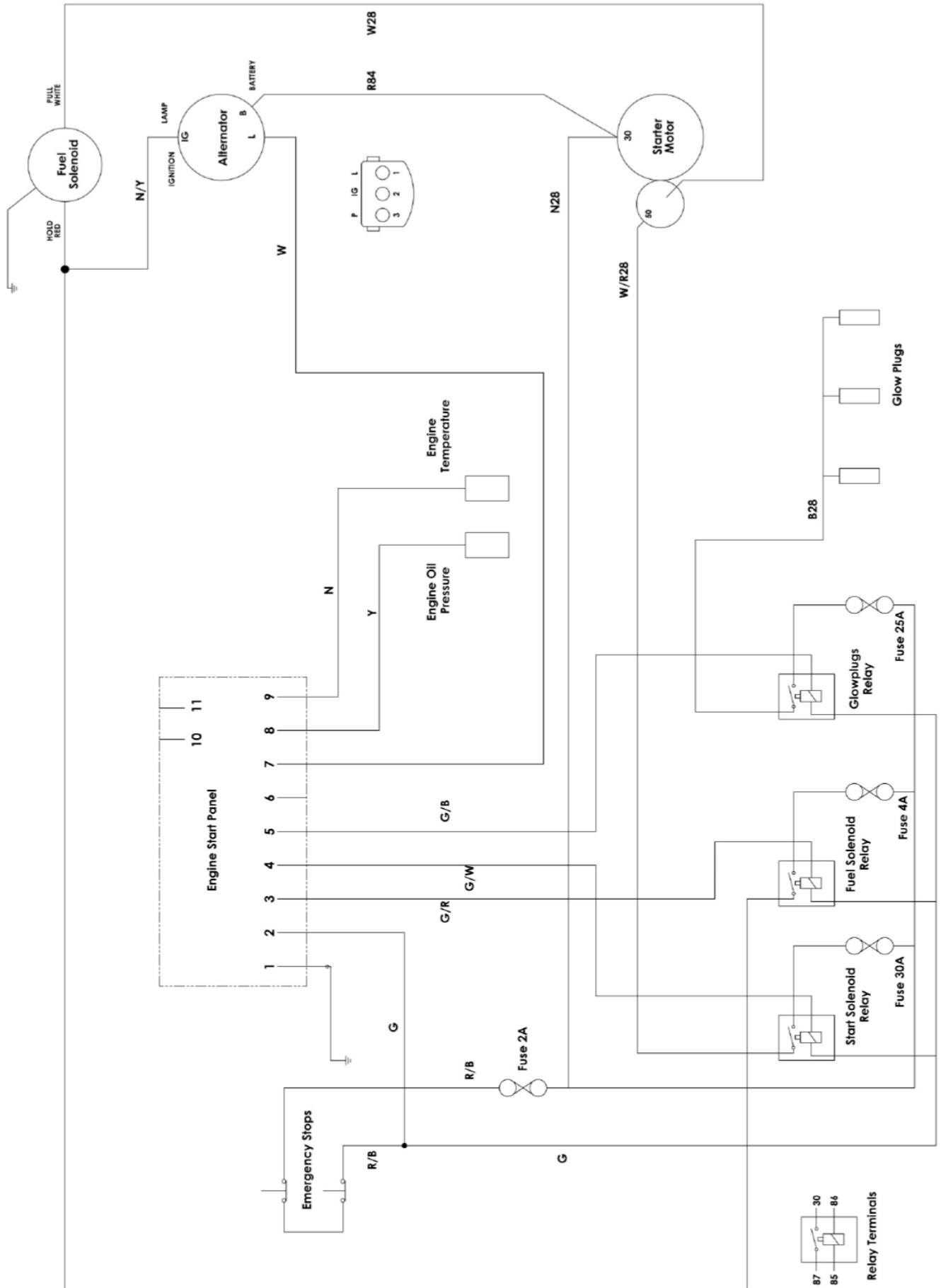

# RED RHINO MINI CRUSHERS (UK)LTD.

## NOISE EMISSION DATA IN ACCORDANCE WITH –

MACHINERY DIRECTIVE 2006/42/EC

OUTDOOR NOISE DIRECTIVE 2000/14/EC

NOMAD (9) 2016 NOISE MACHINERY PROJECT.

## Equipment Type - **RED RHINO MODEL 4000**

THIS EQUIPMENT HAS THE FOLLOWING NOISE EMISSION DATA COMPILED – **NOVEMBER 2022**. UNDER NON- CRUSHING CONDITIONS.

A Weighting – A standard weighting of the audible frequencies designed to reflect the response of the human ear to noise

All measurements were taken in a Hemispherical Order with 1 Meter radius around the Crusher.

MEASUREMENTS 1 – 4 - Ambient background reading machine non – functional

MEASUREMENTS 5 – 8 – Machine Operational at full running speed. All Functions engaged.

POSITION 1 64.4 Sound Level dB (A)

POSITION 2 67... Sound Level dB (A)

POSITION 3 72... Sound Level dB (A)

POSITION 4 73.4 Sound Level dB (A)

POSITION 5 93.3 Sound Level dB (A)

POSITION 6 94.1 Sound Level dB (A)

POSITION 7 92.1...Sound Level dB (A)

POSITION 8 93.9...Sound Level dB (A)

Mean Reading 1 – 4 69.20. dB (A)

Mean Reading 5 – 8 93.35. dB (A)

The noise levels recorded are above the guidance regulations of 80 dB(A)

Owners should enforce the operational use of **Hearing Protection** and conduct their own noise **Risk Assessment** within their operational surroundings.

## **PLEASE BE ADVISED**

These readings were carried out in a non- crushing condition, materials being crushed may produce greater noise levels. Appropriate PPE protection should be applied. Further tests carried out to determine operational levels of noise omitted when materials are being crushed should be carried out by Owner/Operator.

**EDITION NOVEMBER 2022**

# Conclusions/Recommendations for Action

The noise level at the operators position at the controls of the machines is in excess of the second action level of 85dB (A) which under the Control of Noise at Work regulations 2005 action levels requires that hearing protection must be worn (operators of the machine should conduct their own noise exposure risk assessment to determine the risk to anyone operating the machine).

The levels of noise in excess of 80dB (A) produced extend beyond the 1 meter boundary and so all persons working within the 5m boundary should wear hearing protection.

Different materials may produce greater levels of noise and so if there is any doubt about the noise levels, hearing protection should be worn and further measurements should be taken to determine the levels.

Warning signs or labels should be applied to all machines stating that hearing protection must be worn whilst in use even if not crushing. An example is shown below.



**HEARING PROTECTION MUST BE WORN!**

Owners of a Red Rhino machine should carry out further noise testing and risk assessments to reflect the relevant site conditions where the machine is in operation.